

Field Control Layer Device

NFT28U

Group Control Touch Panel

【Description】

The NFT28U group control LCD touch panel is a dedicated field operation man-machine interface for DF series fan coil controllers. It has a two-wire RS485 network communication capability and can be connected with up to 32 fan controllers to form a community network. Through the NFT28U operating interface, users can perform control functions such as start-stop operation, schedule start-stop operation, temperature adjustment, wind speed switching, and timer shutdown of the fan controller in groups, partitions or individually, as well as real-time monitoring of the operation status of each fan. View and check function, with a touch-sensitive LCD backlit screen, and can operate the touch screen to start, stop, change the temperature and humidity settings, etc.), and also has 8 dedicated touch function keys, which can be quickly set. Adopting 32-bit microprocessor to manufacture super powerful functions and superior performance, the transmission distance can reach 1,200 meters.



The NFT28U-Q is a version that incorporates the air quality sensor function. Users can obtain the air quality value in the environment through the NFT28U-Q without having to install an additional air quality sensor. In addition, users can upload media screens through NFTeditor, plan various corporate images or energy-saving promotional screens, and display them when there is no operation to enhance the added value of the product.

【Features】

- It adopts MODBUS communication, which can be connected to the FCnet or SCnet layer communication of AIRTEK DFC series products as the man-machine interface of the controller.
- The 2.8" TFT LCD touch screen can display various information content, with simplified/traditional/English operation display, and menu settings can be switched directly.
- The control screen is divided into the main control screen and the advanced setting screen. The general setting can be controlled by the touch pad on the panel to control the comfortable conditions.
- With advanced settings, there are functions such as mode, sleep comfort, energy saving, scheduled power on/off, timer power off, system settings, password, channel selection, group, and common modes.
- The fan selection function can display the currently connected fans and their power on/off status at one time, so that the user does not need to select one by one to confirm whether it is currently on/off.
- In addition to the overall control, the group control function can also set the partition group. When using it, you can perform related group settings (such as temperature, wind speed) for a specific area.
- The common mode function can save the common settings of each fan in the network, so that the administrator can return all the fans in the network to the common settings with one key operation when necessary.
- You can update the firmware and upload image data through the Mini USB interface.
- With the function of uploading media screens, plan all kinds of corporate images or energy-saving promotion screens, with a maximum of 18 images. You can choose to play or not to play.
- With language, lock, temperature unit, background setting, buzzer, media playback, brightness, clock mode, clock setting adjustment and other parameter setting functions.
- The clock mode setting can accept the network time correction of the central monitoring, and you can also choose the clock to write out, and the panel will display the time, and the connected controller will be synchronized.
- NFT28U-Q contains temperature, humidity, and carbon dioxide sensing functions, which can sense indoor air quality and return its values to the central monitoring network.

【Specification】

Model	Temperature	Humidity	CO ₂	IAQ Display
NFT28U	X	X	X	X
NFT28U-Q	○	○	○	○

Power Supply : 5VDC, 3VA (5VDC power supply provided by V+ and V- on AIRTEK DFC..SCnet can be used).

Display : 2.8" TFT LCD touch screen, full-color 65,536 colors, resolution 320*240 modules.

Microprocessor : 32-bit high-speed arithmetic microprocessor (MCU), containing 64K SRAM and 384K Flash memory space, additional 8M font library and user data memory.

SCnet interface : RS-485 communication interface, the maximum transmission distance is 1,200 meters.

USB interface : Mini USB transmission interface for firmware update and graphic control data download.

Function keys : 8 function keys.  for fan start and stop. ,  for temperature adjustment,  fan speed setting
 Set key for group control. ,  for channel selection button, and  switch for air-conditioning mode.

Buzzer : For operation and alarm prompts.

Environment : 0~50°C, 5~95%RH non-condensing.

Temperature : Temperature/humidity chip, range 0~50°C, accuracy is ±0.4°C (measured at 25°C).

Humidity : Temperature/humidity chip, range is 0~100%RH (non-condensing), accuracy ±3%RH (at 10~90%RH/25°C)

CO₂ : NDIR non-dispersive infrared sensor, range, 0~10,000ppm, accuracy ±40ppm ±3%

Certificate : CE, RoHS

Accessories : HMI-LINKER

【 Application 】

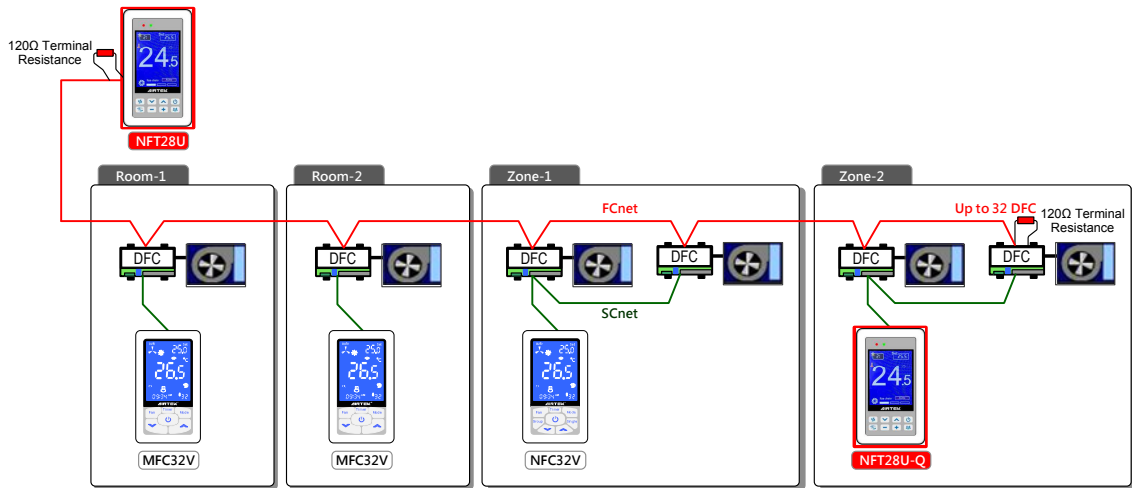

【 Installation 】

- Please read the catalog carefully before installation. Failure to follow the instructions in the catalog may cause danger or cause unpredictable results such as product damage.
- Do not connect the panel to the power supply during installation, because of the danger of electric shock or equipment damage, which may cause personal injury or damage the electrical circuit.
- Please install the control panel on the wall about 1.2 meters above the ground and in a location with good ventilation and circulation. Do not install it in a location that is directly exposed to heat, damp, dusty or vibrating, so as not to affect the control effect or product life.
- The transmission distance between the main communication network FCnet and the sub-communication network SCnet is less than 300 meters. It is recommended to use AWG22~24#2C paired copper mesh to isolate and shield the cable. For more than 300 meters, it is recommended to use AWG18~20#2C paired copper mesh for isolation. The cable must be shielded and must have an impedance of 100~130Ω. The capacitance between the conductor and the conductor must be less than 100 pF per meter. The cable wire between the copper screen of the conductor is less than 200 pF per meter.
- The RS485 communication network must adopt a daisy chain connection mode of one input and one output, and it cannot be divergent or star-shaped, and keep the positive and negative polarity of the potential consistent.
- The front and back ends of the RS485 communication network should be equipped with 120Ω terminal resistors to effectively improve the stability of communication quality. The total length of the network should not exceed 1,200 meters.
- When the group control panel is within 20 meters from the DF.. controller, you can use AWG22~24#4C twisted copper mesh isolation shielded cable to connect (two of the cores are used for connecting to the power supply), and the DF.. controller can be used nearby. 5VDC power supply (terminals V+&V-) on the power supply; if the distance exceeds 20 meters, a 5VDC power supply must be configured independently. Remember! Do not share the power supply with other equipment, so as to avoid the short circuit burnout caused by the difference in circuit design.
- FCnet and SCnet communication networks should be covered with EMT metal conduits, and should not be co-managed with power lines or power lines to avoid noise interference.
- To download the graphic control screen, set the parameters or update the firmware version of the panel, you need to use the computer to run the NFTeditor software to operate. **Notice! Please unplug the external 5VDC power supply before connecting to the computer**, and then connect it to the computer with a Mini USB transmission cable, and use the computer's USB port to directly supply 5VDC, so that the computer and panel information can be transmitted smoothly.

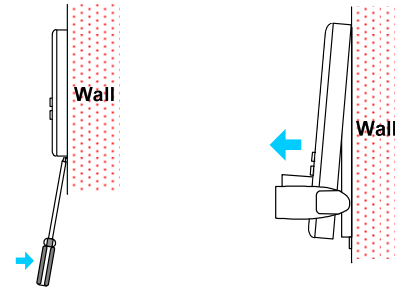
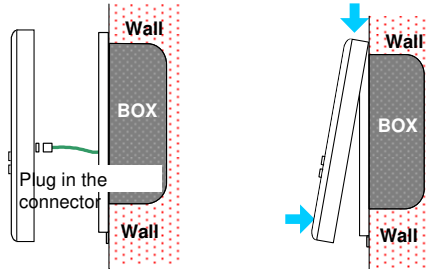
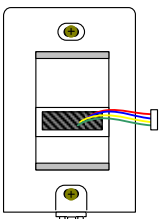
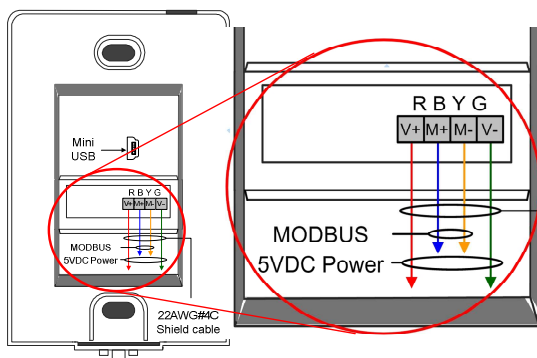

Fig.1 Installation

Fig.2 Dismount

【 Wiring 】



【 Dimensions 】 Unit : mm

