

Field Control Layer Device

MFC32V

Individual LCD Touch Control Panel

【Description】

The MFC32V stand-alone LCD control panel is a dedicated field operation man-machine interface for networked fan coil controllers. It has a two-wire RS485 network communication capability and can communicate with a single fan coil controller. Through the MFC32V operating interface, the user can individually perform manual start-stop operation, schedule start-stop operation (with central monitoring), temperature adjustment, wind speed switching, and timer shutdown control functions on the fan controller, as well as real-time monitoring of the current status of the fan Monitoring and checking functions, such as on-site temperature value, system operation mode, wind speed operation status, fault alarm, etc. MFC32V has a large graphical blue reverse-backlit LCD liquid crystal display screen and touch buttons, which are convenient for users to view, set, change and confirm various control parameter values.



【Features】

- It adopts high-speed computing microprocessor (MCU), which can operate independently.
- Two-wire network communication transmission (including power supply must be equipped with four-core wire), construction and wiring are simple.
- With a large LCD blue reverse backlight display, it can display the fan position of the fan controller, on-site temperature value, set value, wind speed, operation mode, current time value, timer shutdown and alarm abnormal status messages etc.
- Adopting touch button technology, with individual operation air-conditioning mode (automatic, air-conditioning, heating and air supply, etc.) and wind speed switching, energy-saving, and sleep-saving operation functions.
- With 0~12 hours timer shutdown function, which can facilitate the operation of overtime delay in office situations.
- With parameter operation mode, it can operate time setting, time display, temperature unit, key lock, sensing temperature deviation, setting temperature upper and lower limit and other functions.
- With time display function, when connected to the central monitoring, the time can be displayed.
- Designed with Flash memory method, the memory can be maintained for more than ten years without power supply.
- With software program crash self-wake-up function (WATCH DOG).

【Specification】

Model	A/C Mode	Fan Speed	Valve Status Display	Time Display	Timer Shutdown	Transmission distance	Set Scale	Display Scale	Box
MFC32V	Auto/Cooling/Heating/fan	Auto/High/Med./Low	Yes	Yes	0-12hr	1,200M	0.5°C	0.1°C	90*54mm

Power Supply : 5~12VDC, 1VA (5VDC power supply provided by V+ and V- on AIRTEK DFC..SCnet can be used).

Microprocessor : High speed processor.

SCnet Port : 2-wire MODBUS RTU RS-485 bus, max. transmission distance 1,200 meters.

LCD Display : 3.2", 42mm(W)*63mm(H) display size. It has a dynamic graphic display with back light.

Control Range : 0~50°C (32~122°F)

Keypad : 6 operation buttons with key lock function.

Environment : 0~50°C, 5~95%RH non-condense.

Certificate : CE, RoHS.

【Installation】

- Please read the catalog in detail before installation. Failure to follow the instructions in the catalog may cause danger or cause unpredictable results such as product damage.
- Do not connect the panel to the power supply during installation, because of the danger of electric shock or equipment damage, which may cause personal injury or damage the electrical circuit.
- Please install this control panel on the wall about 1.2 meters above the ground and in a location with good ventilation and circulation. Do not install it in a location that is directly exposed to heat, damp, dusty or vibrating, so as not to affect the control effect or product life.
- The transmission distance between the main communication network FCnet and the sub-communication network SCnet is less than 300 meters. It is recommended to use AWG22~24#2C paired copper mesh to isolate and shield the cable. For more than 300 meters, it is recommended to use AWG18~20#2C paired copper mesh for isolation. The cable must be shielded and must have an impedance of ①100~130Ω ②The capacitance between the conductor and the conductor must be less than 100 pF per meter. ③The cable between the copper mesh shield of the conductor should be less than 200 pF per meter.
- The RS485 communication network must adopt a daisy chain connection method with one input and one output, and it cannot be divided or star-shaped, and the positive and negative polarity of the potential must be kept the same.
- The front and back ends of the RS485 communication network should be equipped with 120Ω terminal resistors to effectively improve the stability of the communication quality. The total length of the network should not exceed 1,200 meters.
- When the group control panel is within 20 meters from the DF.. controller, you can use AWG22~24#4C twisted copper mesh isolation shielded cable to connect (two of the cores are used for connecting to the power supply), and the DF.. controller can be used nearby. 5VDC power supply (terminals V+&V-) on the power supply; if the distance exceeds 20 meters, a 5VDC power supply must be configured independently. Remember! Do not share the power supply with other equipment, so as to avoid the short circuit burnout caused by the difference in circuit design.
- FCnet and SCnet communication networks should be covered with EMT metal conduits, and should not be co-managed with power lines or power lines to avoid noise interference.

[Wiring Diagram]

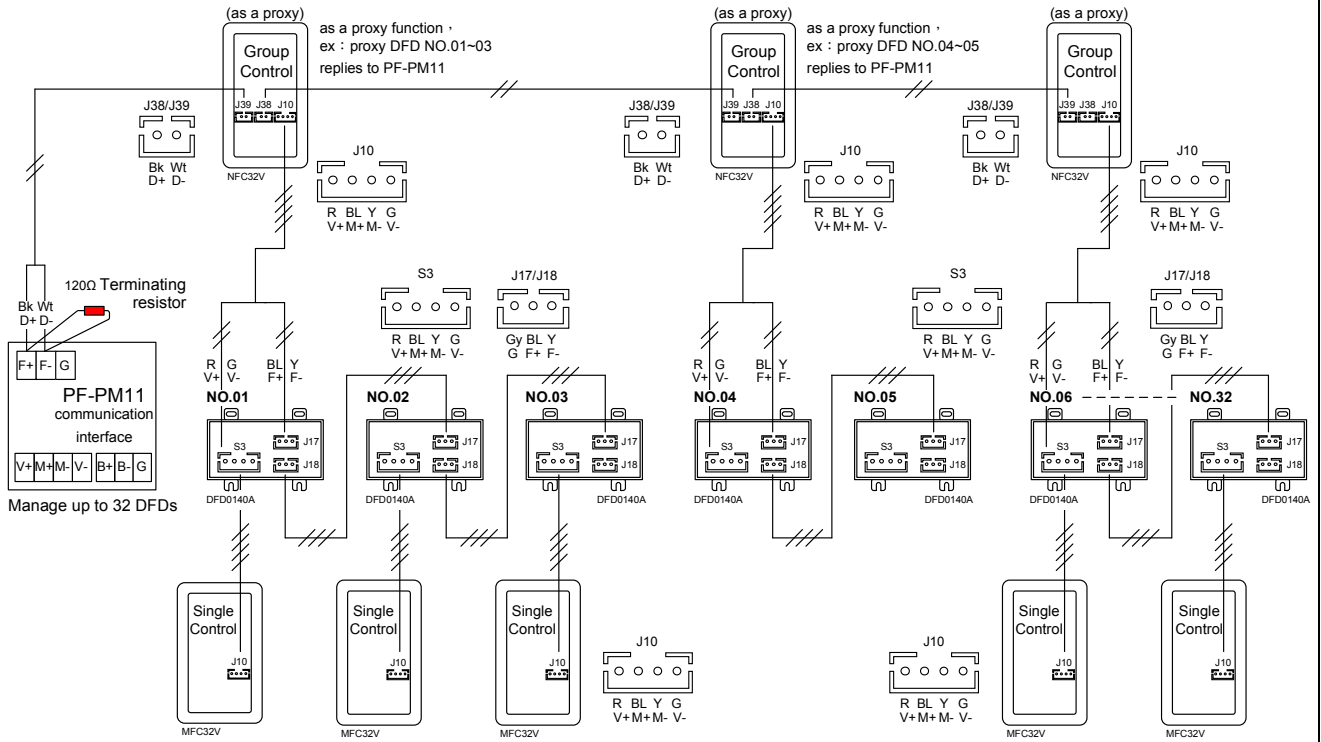

[Network Architecture]

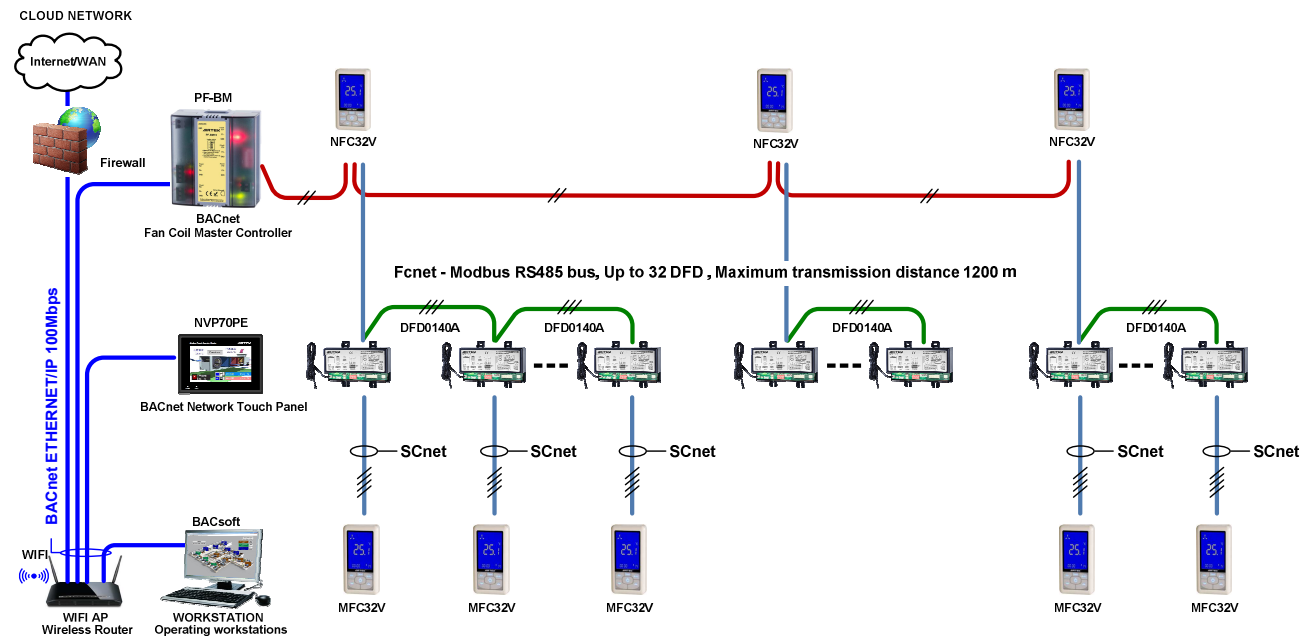

[Dimensions] Unit : mm

