

Field Control Layer Device

NFC32V

Group LCD Touch Control Panel

【Description】

NFC32V is DF series networking Fan Coil Unit controller dedicated on-site operation man-machine interface. It has a two-wire RS485 network communication ability, up to 32 DF controllers can be connected to an area network. Users can use NFC32V to operate any controller on the network by group or individual manner, for example, to perform a manual start-stop operation, set the air condition mode, set temperature setpoint, change the fan speed and enable the timer shutdown functions. It also may facilitate the user to examine, setting, change and confirm each kind of control parameter value from any controller in the network, for example the present temperature value, temperature setting, air conditioning mode, fan speed, off timer and alarm messages. NFC32V has a large-scale graphic LCD with backlight and capacitive sensing buttons, let user operate easily and friendly.



【Features】

- 16 bit microprocessor, high precise operation.
- Two-wire communication network, Easy for wiring.
- The large-scale LCD is good for display temperature value, setting value, fan speed, air conditioning mode and abnormal state.
- A touch-button technology, with group and individual air-conditioning mode (automatic, air conditioning, heating, and air supply, etc.) with fan speed switching operation function (auto, high, medium and low speed, etc.).
- Has the 0~24 hour power off timer, may facilitate the overtime work situation.
- With the parameter mode of operation, operational key lock function of temperature units, time mode etc.
- With real-time clock function to display the time now.
- Flash memory design, keep memorize for more than ten years without power.
- Included self-wakeup function (Watch Dog) when software is down.

【Specification】

| Model | A/C Mode | Fan Speed | Time Display | Timer | Control | Valve feedback | Distance | Set Scale | Display Scale | Box |
|--------|--------------------------|--------------------|-----------------------|--------|------------|----------------|----------|-----------|---------------|----------|
| NFC32V | Auto/Cooling/Heating/Fan | Auto/High/Med./Low | Get time from network | 0-12hr | 32 Devices | Yes | 1,200M | 0.5°C | 0.1°C | 90*54 mm |

Power Supply : 5VDC, 35mA. (Power sources offer by DF. controller.)

Microprocessor : 16 bit high speed processor.

FCnet Port : 2-wire MODBUS RTU RS-485 bus, communication speed 9,600 bps, max. transmission distance 1,200 meters.

SCnet Port : 2-wire MODBUS RTU RS-485 bus, communication speed 9,600 bps, max. transmission distance 1,200 meters.

LCD Display : 45mm(W)*63mm(H) display size. It has a dynamic graphic display with back light.

Hardware Clock : Real-time clock inside with capacitance power outage redundant design.

Control Range : 15~32°C (59~89.6°F)

Keypad : 8 operation buttons with key lock function.

Environment : 0~50°C, 5~95%RH non-condense.

Certificate : CE(EMC Directive 2004/108/EC)

【Installation】

- Please read the catalog in detail before installation. Failure to follow the instructions in the catalog may cause danger or cause unpredictable results such as product damage.
- Do not connect the panel to the power supply during installation, because of the danger of electric shock or equipment damage, which may cause personal injury or damage the electrical circuit.
- Please install this control panel on the wall about 1.2 meters above the ground and in a location with good ventilation and circulation. Do not install it in a location that is directly exposed to heat, damp, dusty or vibrating, so as not to affect the control effect or product life.
- The transmission distance between the main communication network FCnet and the sub-communication network SCnet is less than 300 meters. It is recommended to use AWG22~24#2C paired copper mesh to isolate and shield the cable. For more than 300 meters, it is recommended to use AWG18~20#2C paired copper mesh for isolation. Shield the cable, and it must have a resistance of ①100~130Ω ②The electric capacity between the conductor and the conductor must be less than 100 pF per meter. ③The cable wire between the copper mesh shielding of the conductor is less than 200 pF per meter.
- The RS485 communication network must adopt a daisy chain connection method with one input and one output, and it cannot be divided or star-shaped, and the positive and negative polarity of the potential must be kept the same.
- The front and back ends of the RS485 communication network should be equipped with 120Ω terminal resistors to effectively improve the stability of the communication quality. The total length of the network should not exceed 1,200 meters.
- When the group control panel is within 20 meters from the DF. controller, you can use AWG22~24#4C twisted copper mesh isolation shielded cable to connect (two cores are used for connecting to the power supply), and the nearest DF. controller can be used. 5VDC power supply (terminals V+&V-); if the distance exceeds 20 meters, an independent 5VDC power supply must be configured for power supply. Remember! Do not share the power supply with other equipment, so as to avoid the short circuit burnout caused by the difference in circuit design.
- FCnet and SCnet communication networks should be covered with EMT metal conduits, and should not be co-managed with power lines or power lines to avoid noise interference.

[Wiring Diagram]

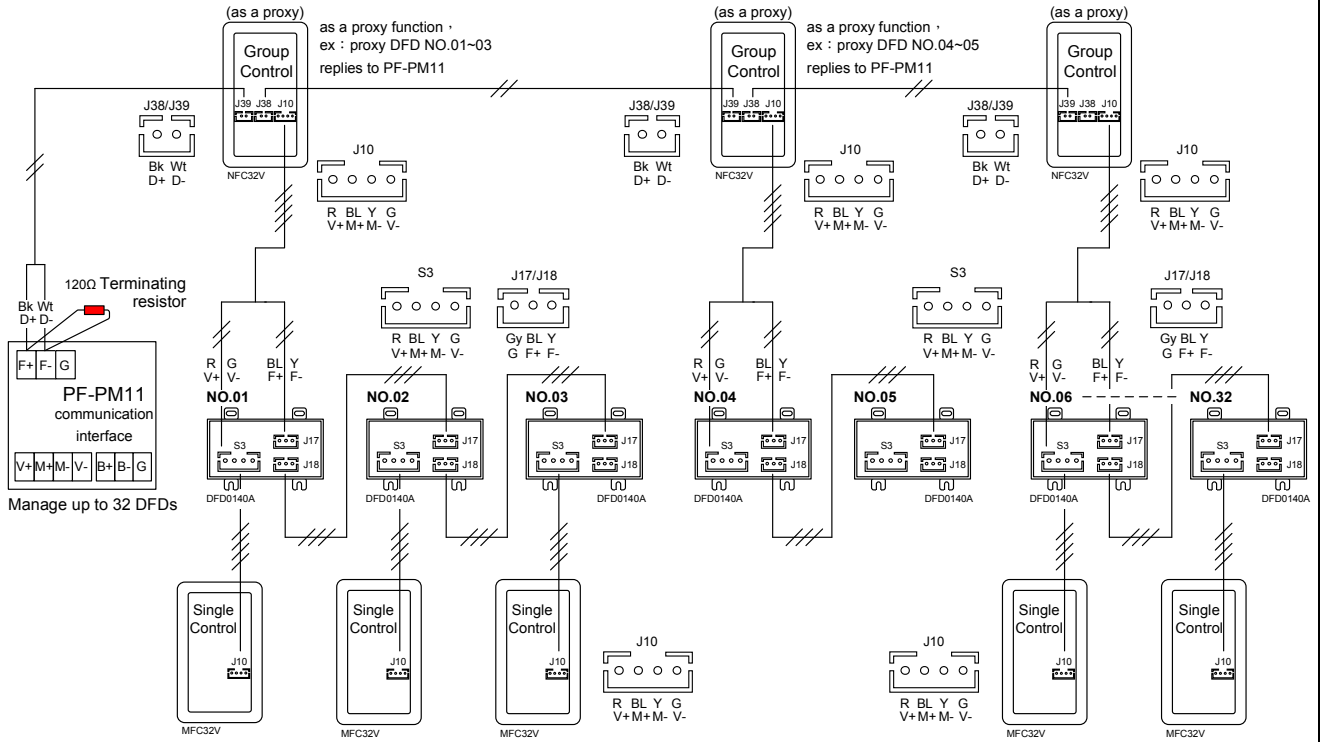

[Network Architecture]

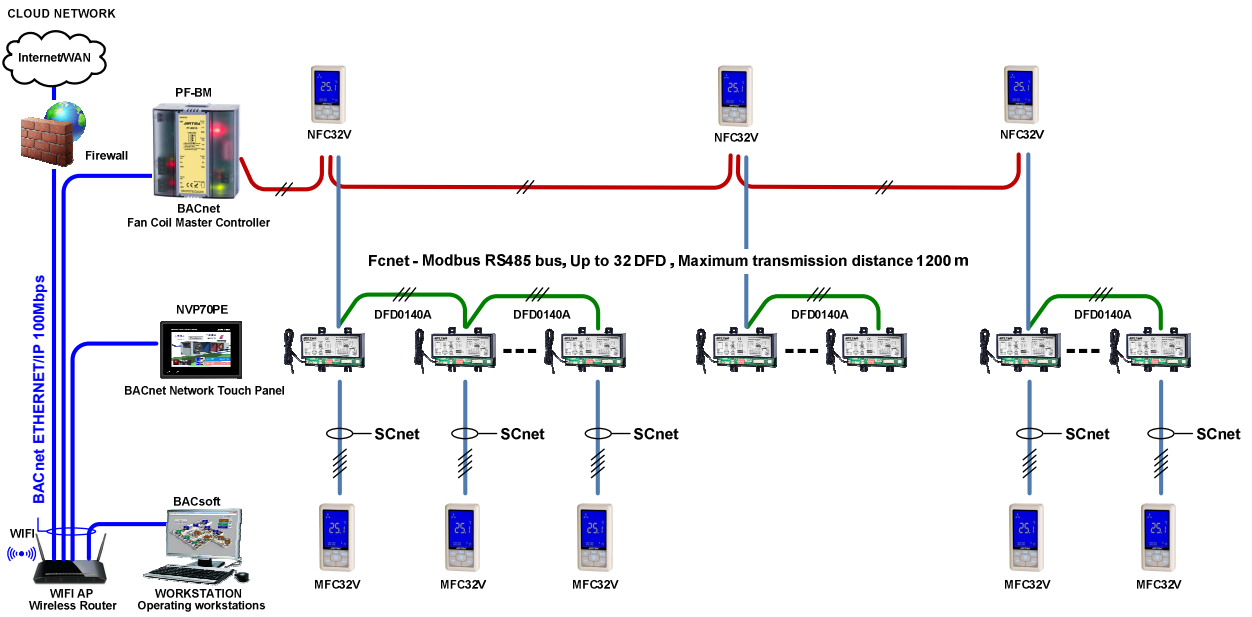

[Dimensions] Unit : mm

