

# Field Control Layer Device

## BACnet Application Specific Controller

# DSCB

### 【Description】

The DSCB is an advanced, programmable, standalone logic controller that complies with the BTL B-ASC protocol specifications. It is designed for monitor and control building electromechanical device, such as large AHU, pumps, fans, exhaust cabinets and other equipment. It uses 32-bit microprocessor core, communication up to 76,800 bps, transmission distance up to 1,200 meters. DSCB doesn't have I/O point. It must be configured EIM expansion I/O. Up to 12 EIM modules can be connected to it. Total number of I/O points can be selected by using different combinations of EIM. In addition, it has an MSnet port can connect to an external LCD control panel to make user operation and control easily at the job site. DSCB conforms international BACnet MS/TP communication protocol, and fully compatible with any BACnet system. It is absolutely the best product for your building.



### 【Features】

- Produced in accordance with the BTL B-ASC protocol specifications.
- MS/TP(Master-Slave/Token-Passing) communication interface connect to the upper layer, global controller.
- MSnet communication interface can connect an MST..., DSP..., DST... control panel.
- EIMnet communication interface can connect up to 12 EIM I/O expansion modules.
- RS-232, the AD-Linker connection line and hyper terminal program can do parameter modification.
- With online program editing, debugging, download, and firmware update functions.
- Carry out calculations such as proportional, integral, differential, floating, logic, arithmetic and etc.
- 150 Binary Value (BV) and 150 Analog Value (AV) points.
- Priority control array by 16 for all BO, AO and BV.
- The analog value adopts high precision floating-point calculation.
- Provide power failure backup functions for all AI/BO/AO/BV/AV values keep in FRAM for at least 10 years.
- Slide track design for space-saving and easy installation.

### 【Specification】

Model	MS/TP Port	MSnet Port	EIMnet Port	EIM Q'TY	BV Points	AV Points
DSCB	1	1	1	12	100	100

**Power Supply:** 24VDC/AC, 2VA.

**Microprocessor:** 32-bit high performance MCU, 20K RAM, 8K FRAM and 128K Flash memory.

**MS/TP Port:** 2-wire MS/TP RS-485 bus, communication speed 9,600/ 19,200/ 38,400/ 76,800 BPS, auto select, max. length 1,200 meters, having 2500Vrms optical coupling isolator and TVS ARRAY surge protection.

**MSnet Port:** 2-wire MODBUS RTU RS-485 bus, communication speed 9,600/ 19,200/ 38,400 BPS, can connect a control panel.

**EIM Port:** RS-485, communication speed 38,400 BPS, max. length 1,200 meters, up to 12 EIMs.

**Environment:** 0~50°C, 5~95%RH, non-condensing

**Certification:** CE certified and compliant with the BTL B-ASC protocol specifications and RoHS

**[ Network Architecture ]**

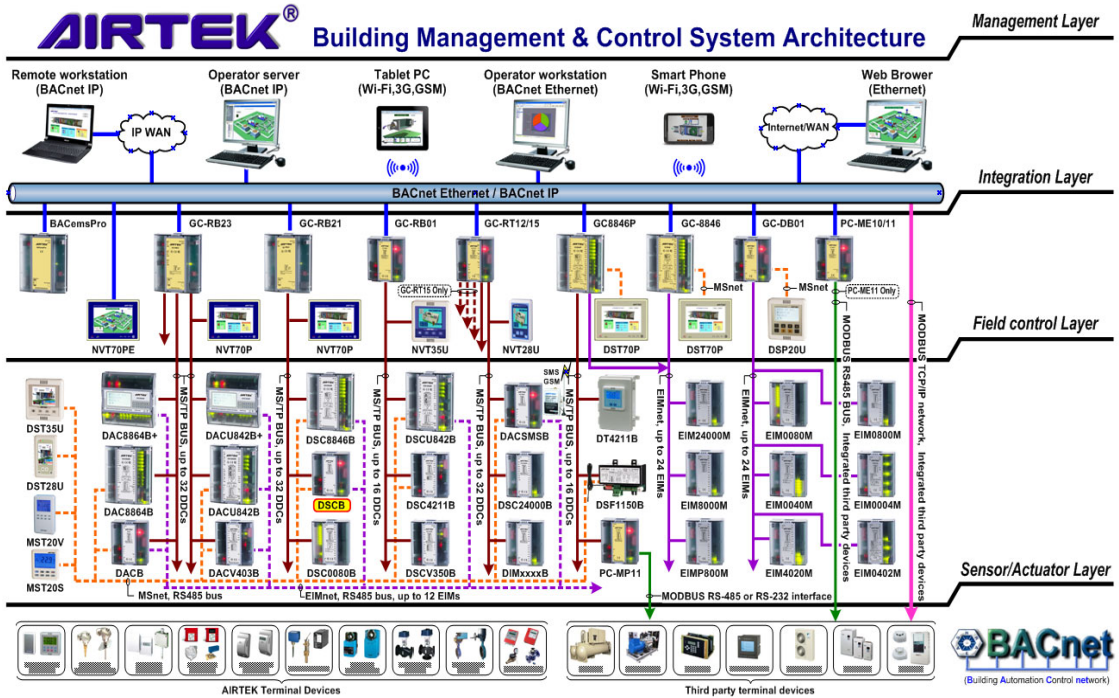

**[ Wiring Diagram ]**

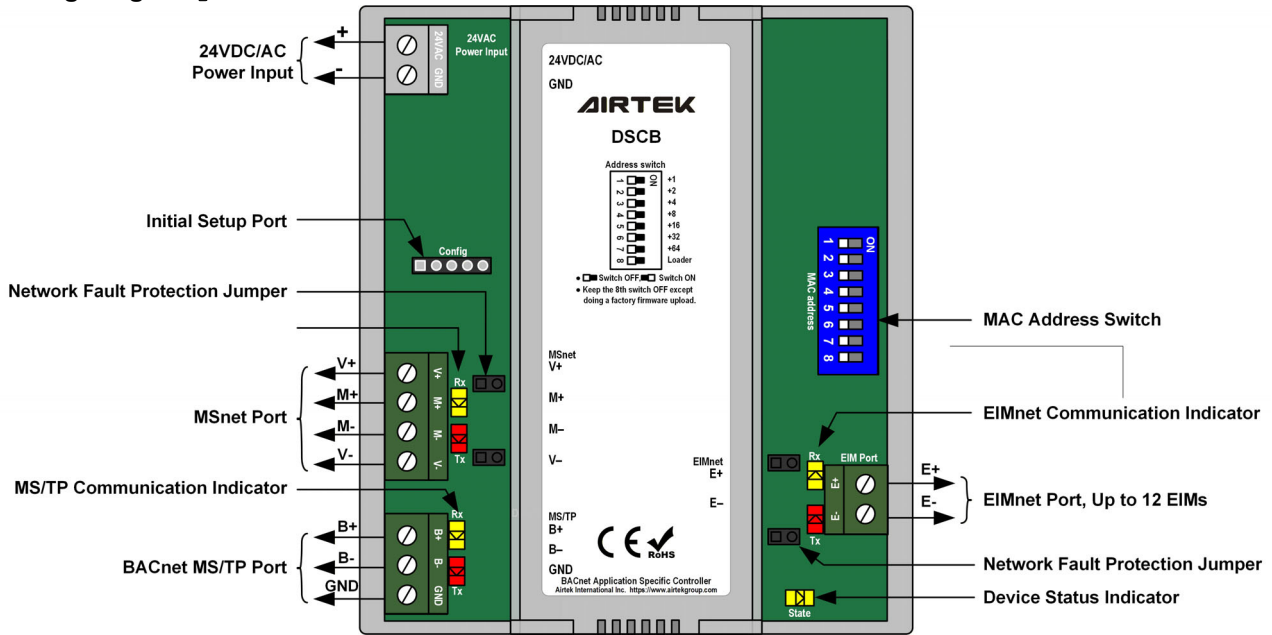

**[ Dimension ] Unit : mm**

