

Integration Layer Device

WC8846P

Web Embedded BACnet Building Controller

【Description】

WC8846P is a BTL BACnet B-BC certified building controller with Web Embedded OS, Router, Programmable, Stand alone, and supports Schedule, Calendar, BACnet standard objects such as Schedule, Calendar, and Event enrollment are supported. It can be used to monitor and control the electrical and mechanical equipment in the building, such as air-conditioning boxes, pumps, fans, exhaust cabinets.... etc. The BACsoft software screen can be translated into a web page format to provide users of the Intranet or Internet with the ability to manage the building's M&E equipment anytime, anywhere via the 3C device's browser.

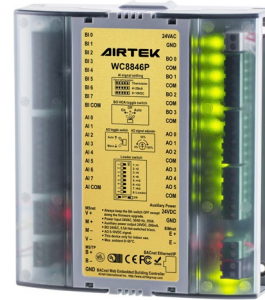

【Features】

- Manufactured in accordance with the BACnet communication protocol established by the American Society of Heating, Refrigerating and Air-Conditioning Engineers (ASHRAE) and certified to BTL B-BC level.
- Peer to Peer data transmission and sharing function and programmable, independent operation, alarm and event management, calendar, timetable, trend record, device and network management functions.
- Built-in Web Embedded operating system, compatible with desktop computers, notebook computers, tablet computers, smart phones and other hardware. In addition, it can be operated with AIRTEK's dedicated cell phone app, which makes the monitoring system have a more convenient and comfortable operating environment and interface when monitoring the system through the cell phone.
- Built-in MS/TP master and servant token communication interface, with 2,500Vrms anti-interference potential isolation design.
- Built-in RS-232 communication interface, through the AD-Linker connection line and hyper terminal machine program, the initial value of the device can be set or parameter modification.
- Digital input point (BI), with 5,000Vrms anti-interference optical coupling isolation capability and status indicator design.
- Analog input with 16-bit resolution, can accept 3K or 10KΩ NTC thermistor, 4~20mA or 0~10VDC and other signals.
- Digital output with 24VAC, 0.5A, hot-switched triacs (Hot-switched triacs), with 7,500Vpeak anti-interference optical coupling isolation device, status indicator light and HOA (manual/stop/automatic) switch And with the switching state feedback monitoring function.
- Analog output point (AO), with 16-bit resolution, 0~10VDC output signal, with HA (manual/automatic) switch and with switching state feedback monitoring function and manual signal output adjustment knob to facilitate on-site test run adjustment and maintenance work..
- With online program editing, debugging, online program download and online firmware update functions.
- It has functions of common HVAC functions such as enthalpy, dew point temperature, PID control, and advanced mathematical functions such as logarithm, trigonometric function, and root sign.
- It has 1,000 digital software points (BV) and 1,000 analog software points (AV), which can be used as calculation values, set points, timers or warning points.
- All values and software points have power failure memory function, which can be written into FRAM automatically when power failure occurs, and the data can be stored for more than 10 years.
- All BO, AO and BV points support 16-bit priority control function.
- With the AIRTEK WC-Recorder tool, the required data can be automatically converted into an Excel file and saved to the PC in units of days or months for use as long-term data storage and subsequent analysis applications.
- E-mail and Line alarm push function; different alarms can be set and notified to different E-mail and Line users.
- With JSON data conversion function, you can set the BACnet information in the system to the corresponding JSON format for reading, which is convenient for BACnet system to integrate with third-party cloud/big data analysis software platforms.

【Specification】

Model	BI	AI	BO	AO	MS/TP	EIMnet	Calendar	Schedule	Notification	Alarm	Trend-log
WC8846P	8	8	4	6	32	24	20	200	20	200	200
WC8846P-S	8	8	4	6	4	12	2	20	2	20	20

Power Supply: 24VAC, 35VA.

Microprocessor: 32-bit dual-CPU microprocessor (MCU), containing 512K FRAM, 64MB SDRAM and 128MB Flash memory.

Binary Input (BI): 12VDC detection voltage, 5,000Vrms anti-interference optical coupling isolation capability, accept dry contact or open collector input signal.

Analog Input (AI): 16-bit resolution, can accept 3K or 10KΩ NTC thermistor, 4~20mA or 0~10VDC and other signals.

Binary Output (BO): 24VAC, 0.5A, Hot-switched triacs with 7,500Vpeak anti-interference opto-coupler isolation, Status indicator and HOA (manual/stop/automatic) switch with switching status feedback monitoring function.

Analog Output (AO): 16-bit resolution, 0~10VDC output signal, with HA (manual/automatic) switch and with switching status feedback monitoring function and manual signal output adjustment knob.

Ethernet Port: 100M Ethernet communication interface, you can choose BACnet Ethernet or BACnet/IP communication layer communication mode. When connecting to an external network, a physical firewall must be installed.

MS/TP Port: RS-485 communication interface, built-in anti-interference isolator with rated isolation voltage of 2,500Vrms and maximum working isolation voltage of 560Vpeak. 32 controllers can be connected, the communication rate is 9,600/19,200/38,400/76,800 BPS can be selected, and the transmission distance is 1,200 meters.

MSnet Port: RS-485 communication interface, which can be connected to a man-machine control panel, the communication rate is 9,600/19,200/38,400 BPS optional, The transmission distance is 1,200 meters.

EIMnet Port: The RS-485 communication interface can be connected to 24 EIM.M expansion modules, the communication rate is 38,400 BPS, and the transmission distance is 1,200 meters.

Auxiliary power out: 24VDC, 200mA, for sensor use.

Clock: Real-time Clock with Gold Capacitor Uninterruptible Backup Design for normal operation after power failure.

Environment: 0~50°C, 20~90%RH, non-condensing

Certification: It has passed BTL (B-BC), UL916, FCC, CE certification and meets RoHS environmental protection standards.

【 Network Architecture 】

BACnet Ethernet to RS-485 Data Router

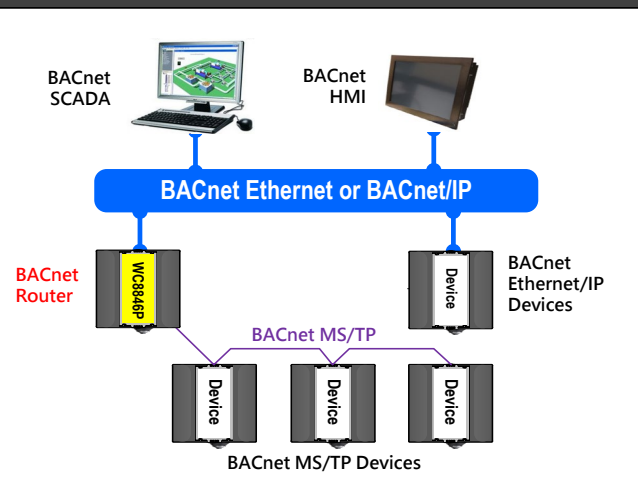

Field Control with EIM I/O

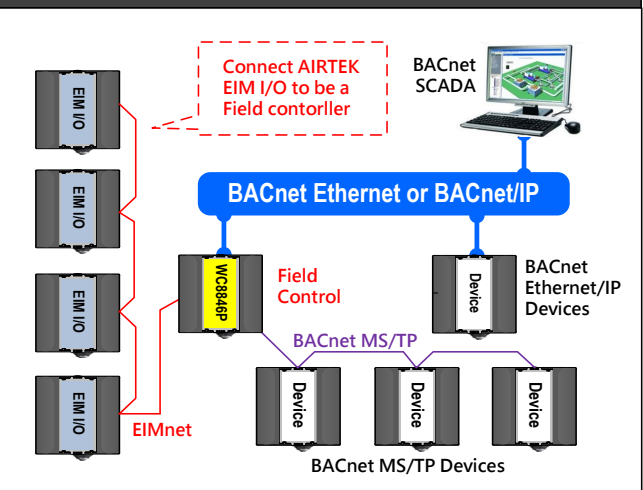

Web Browser system monitor

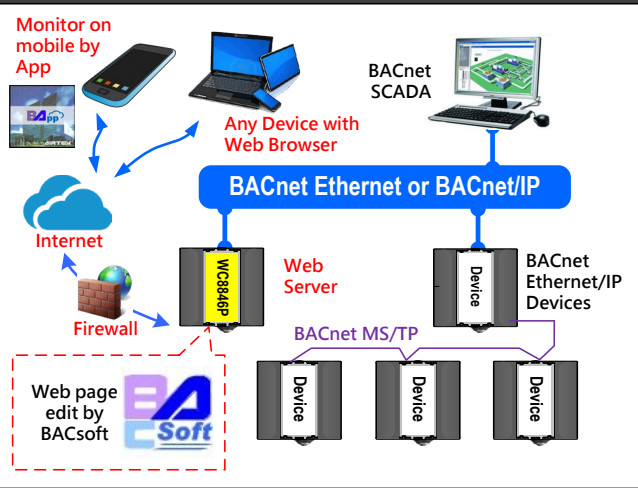

System Data logger (with WC-Recorder)

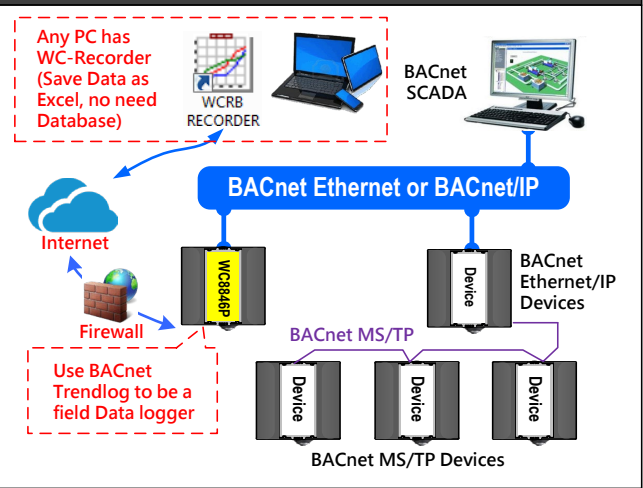

Multi ways to transmit System alarm(email,Line)

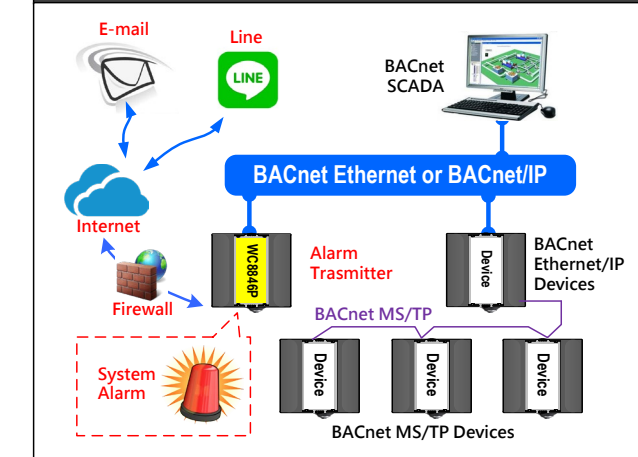

JSON frame for IOT integration

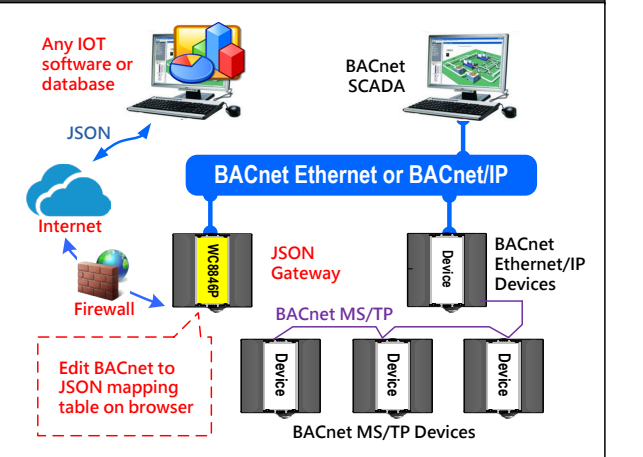

[Wiring Diagram]

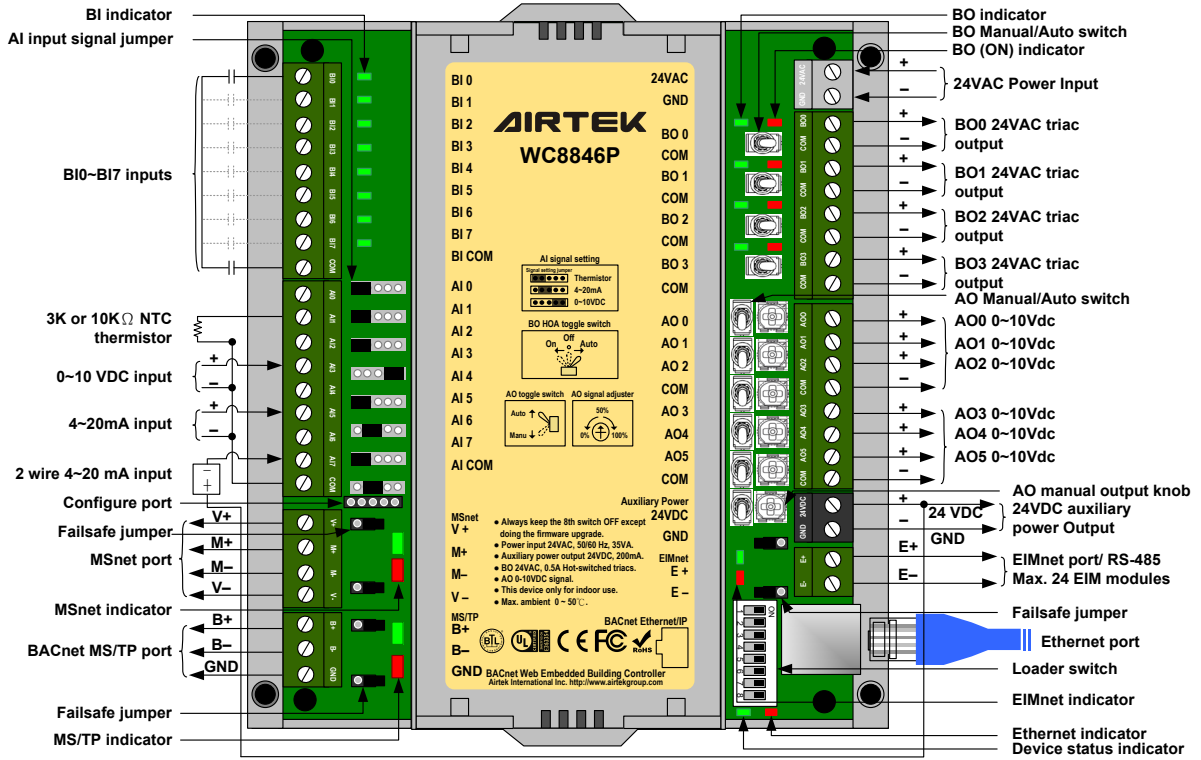

[Dimension] Unit : mm

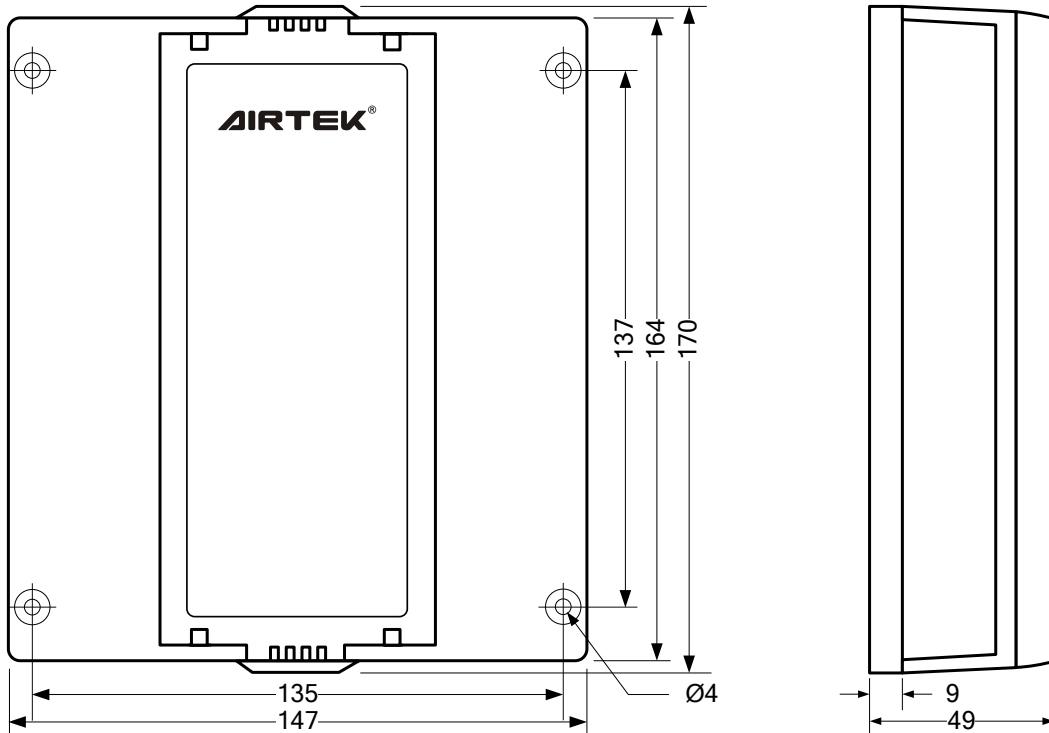

Please refer to <https://www.airtekgroup.com/> for the most recent update information.